

CL 7260 and Pallet Burner Showing PEX Piping Options

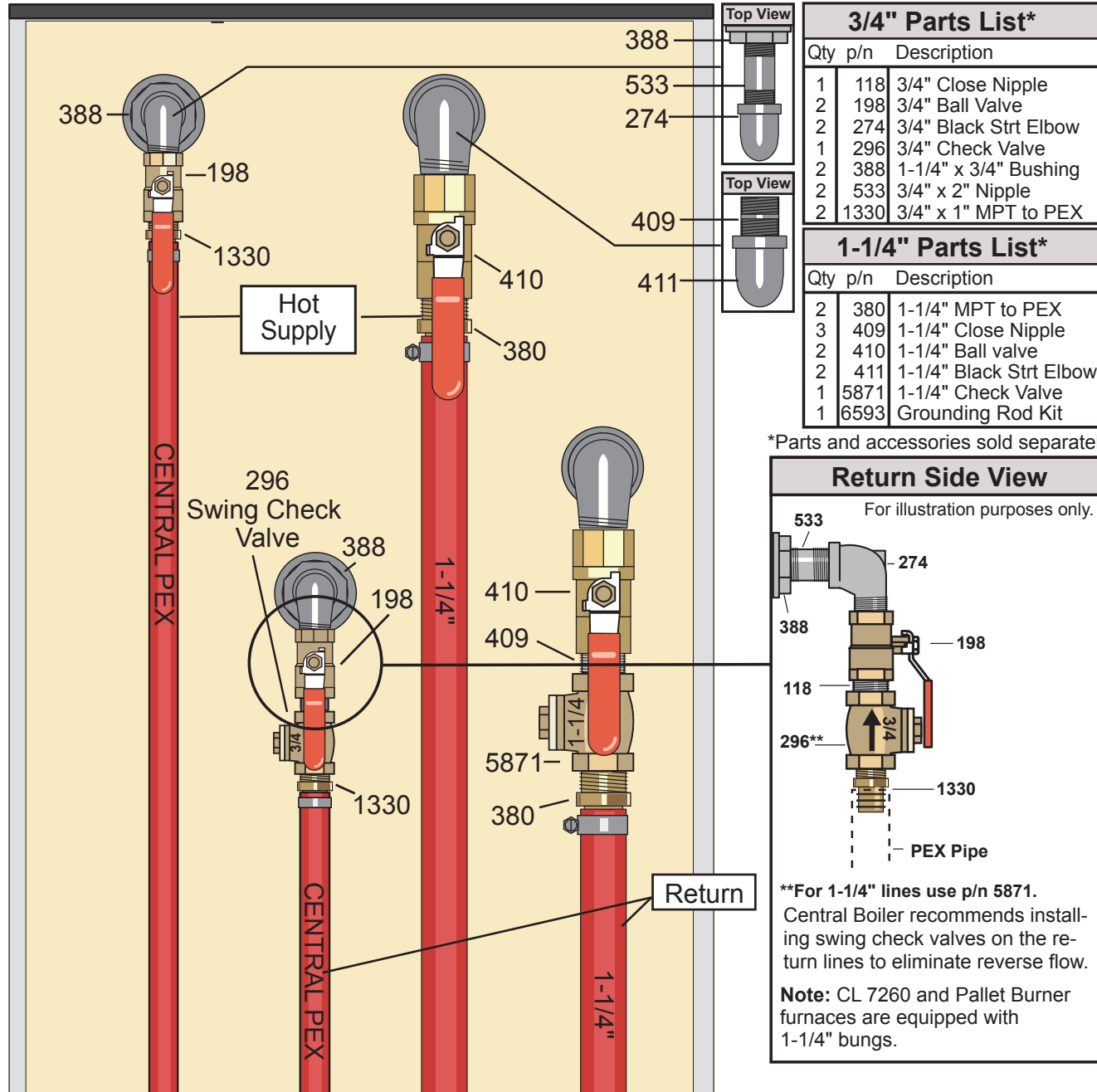

3/4" Parts List*

Qty	p/n	Description
1	118	3/4" Close Nipple
2	198	3/4" Ball Valve
2	274	3/4" Black Strt Elbow
1	296	3/4" Check Valve
2	388	1-1/4" x 3/4" Bushing
2	533	3/4" x 2" Nipple
2	1330	3/4" x 1" MPT to PEX

1-1/4" Parts List*

Qty	p/n	Description
2	380	1-1/4" MPT to PEX
3	409	1-1/4" Close Nipple
2	410	1-1/4" Ball valve
2	411	1-1/4" Black Strt Elbow
1	5871	1-1/4" Check Valve
1	6593	Grounding Rod Kit

*Parts and accessories sold separately.

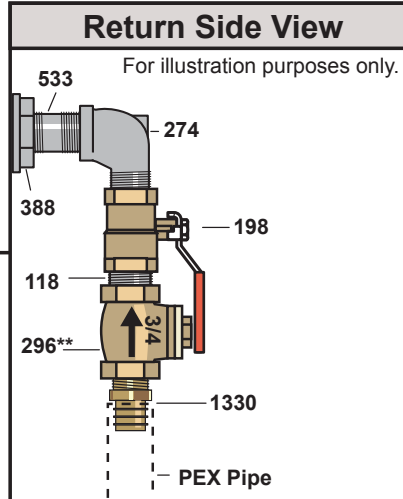

**For 1-1/4" lines use p/n 5871.
 Central Boiler recommends installing swing check valves on the return lines to eliminate reverse flow.
Note: CL 7260 and Pallet Burner furnaces are equipped with 1-1/4" bungs.

